

CAADRE

**300 - 400 - 444 - 500 - 610
- 612 - 640 - 645 - 650**

Cod.7.003.Rev.03 data: 27/03/20

SCHEDA PRODOTTO
PRODUCT INFORMATION
FICHE PRODUIT
PRODUKTDATENBLATT

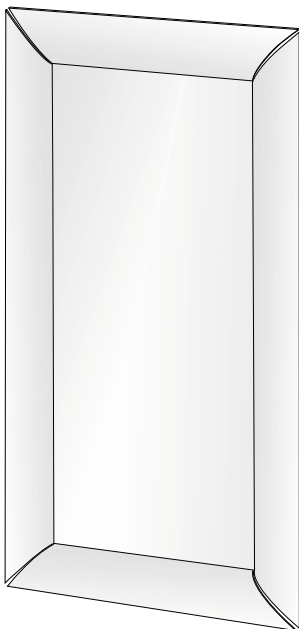

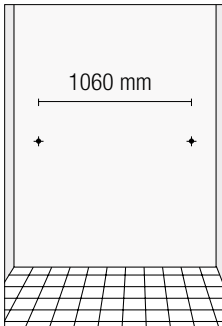
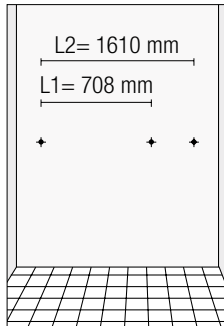
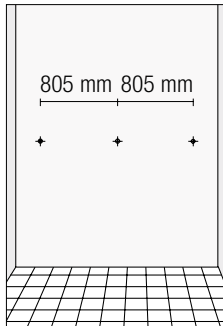
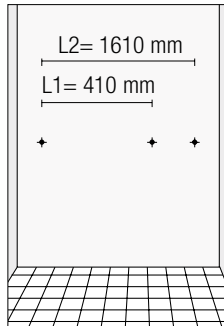
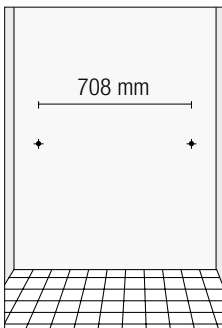
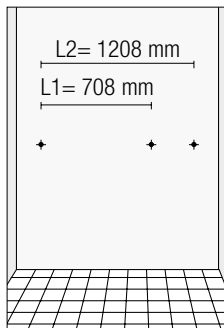
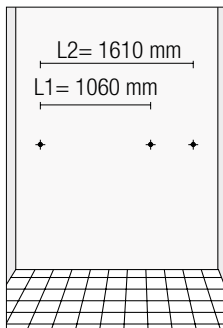
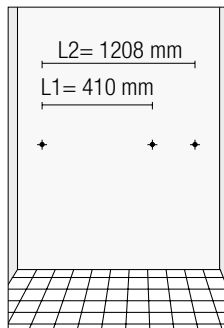
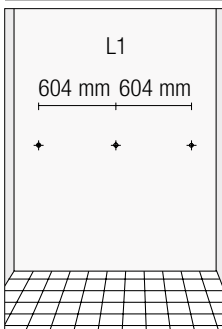
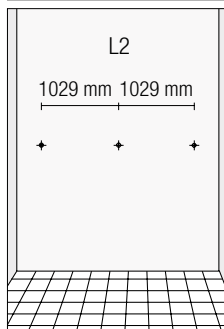
Art. 300**Art. 400****Art. 444****Art. 500****Art. 610****Art. 612****Art. 640****Art. 650****Art. 645****Art. 645**

Praticare i fori alla distanza L1 per la posizione verticale e a L2 per la posizione orizzontale.

Drill the two holes at a distance of L1 for the vertical position and of L2 for the horizontal one.

Perforer les deux trous à la distance du L1 pour la position verticale et du L2 pour celle horizontale.

Um der Spiegel vertikal zu hängen, löchern Sie die zwei Bohrung in einer Entfernung von L1 durch.

Um der Spiegel horizontal zu hängen, löchern Sie die zwei Bohrung in einer Entfernung von L2 durch.

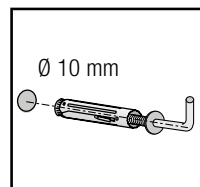

1

Piedini dentro l'imballo
Feet inside the crate
Pieds dans la caisse
FüÙe in der Kiste

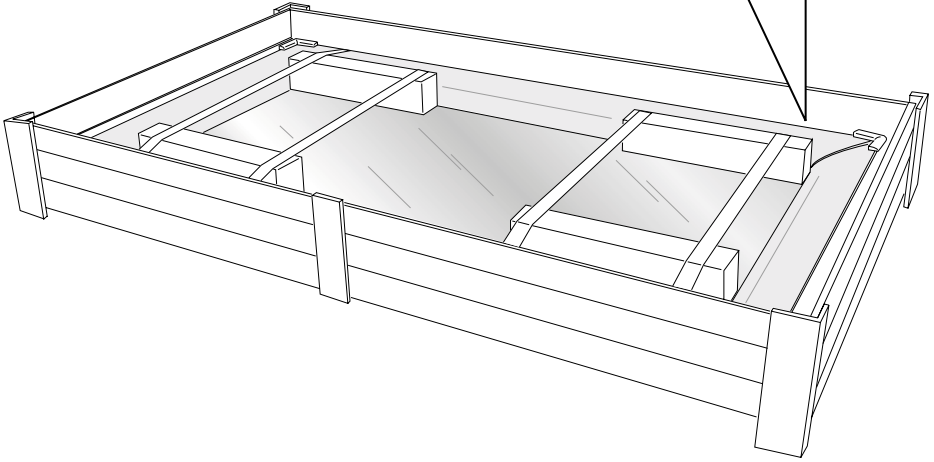
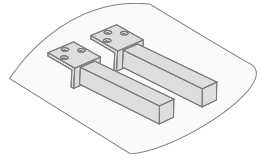
**2**

Assicurarsi di avere una buona presa sul telaio e sulla cornice prima di sollevare lo specchio.

Before raising the mirror, make sure that the grip on the iron and glass frame is tight.

Avant de soulever le miroir, assurer la prise du cadre et de la structure en fer.

Vor Spiegelaufheben, sich versichern den starken griff der Rahmen und des Eisengestells.

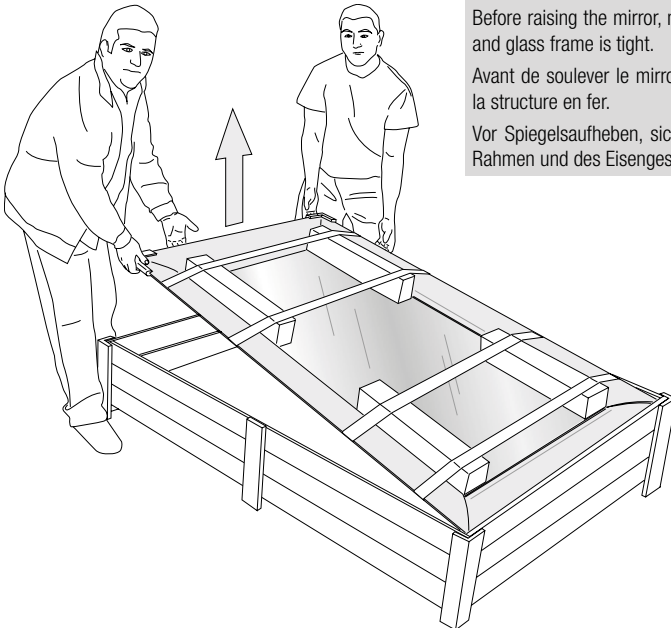

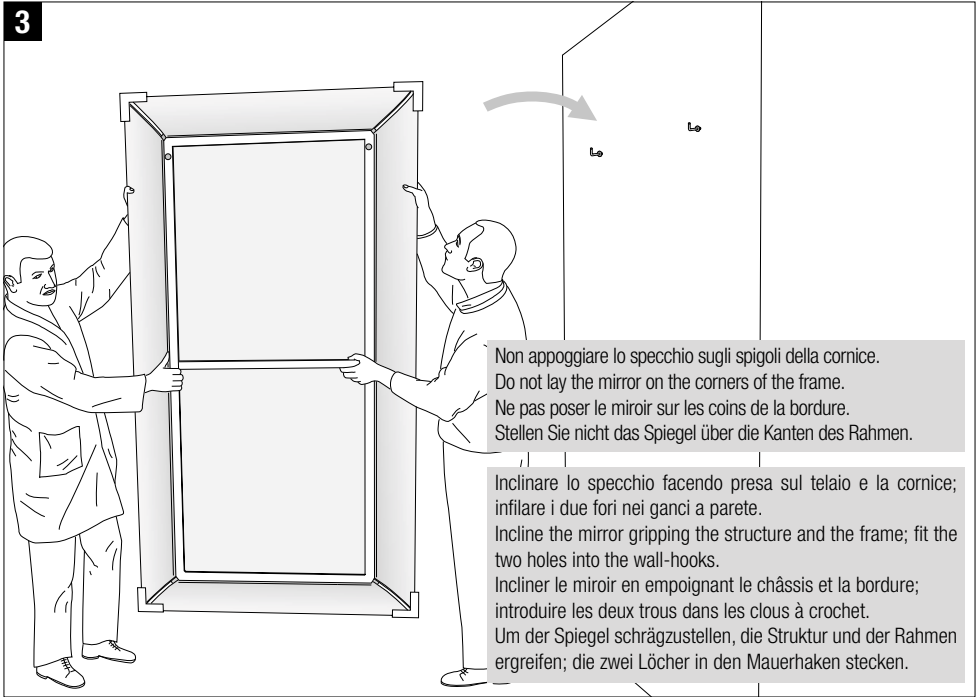
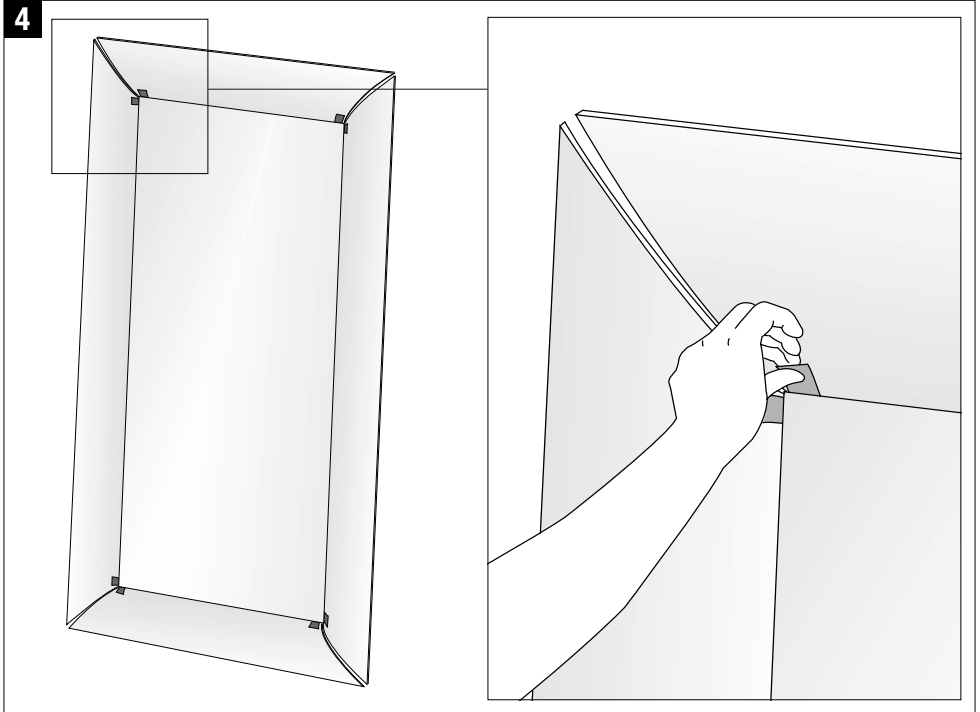
3**4**

CAADRE FREESTANDING

Art. 400 - 444 - 500 - 640 - 645

1

Assicurarsi di avere una buona presa sul telaio e sulla cornice prima di sollevare lo specchio.
Before raising the mirror, make sure that the grip on the iron and glass frame is tight.
Avant de soulever le miroir, assurer la prise du cadre et de la structure en fer.
Vor Spiegelsaufheben, sich versichern den starken griff der Rahmen und des Eisengestells.

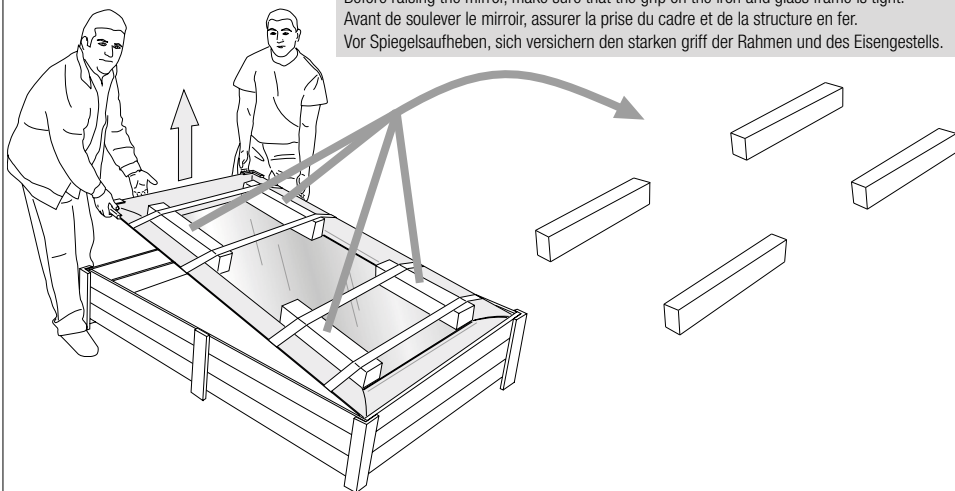

2

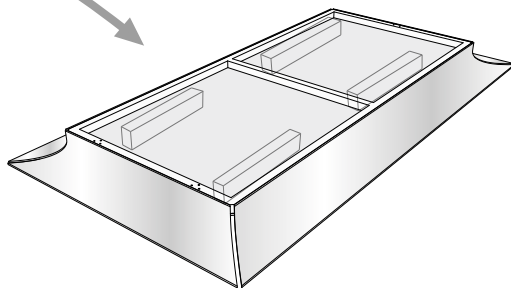
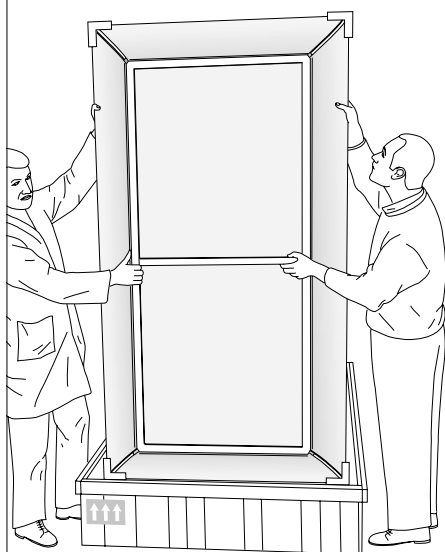

Non appoggiare lo specchio sugli spigoli della cornice.
Do not lay the mirror on the corners of the frame.
Ne pas poser le miroir sur les coins de la bordure.
Stellen Sie nicht das Spiegel über die Kanten des Rahmen.

3

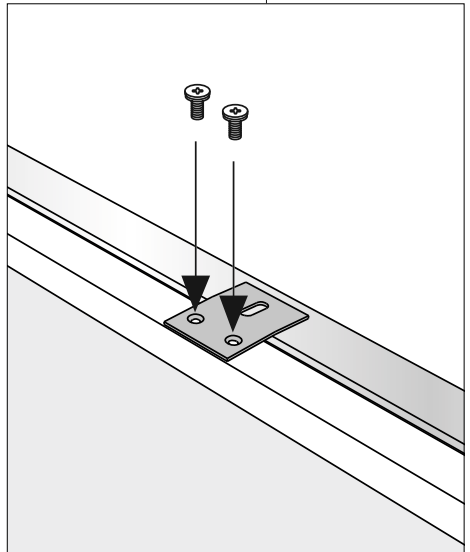
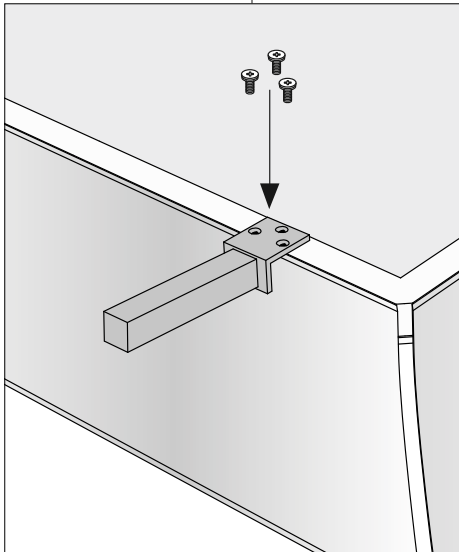
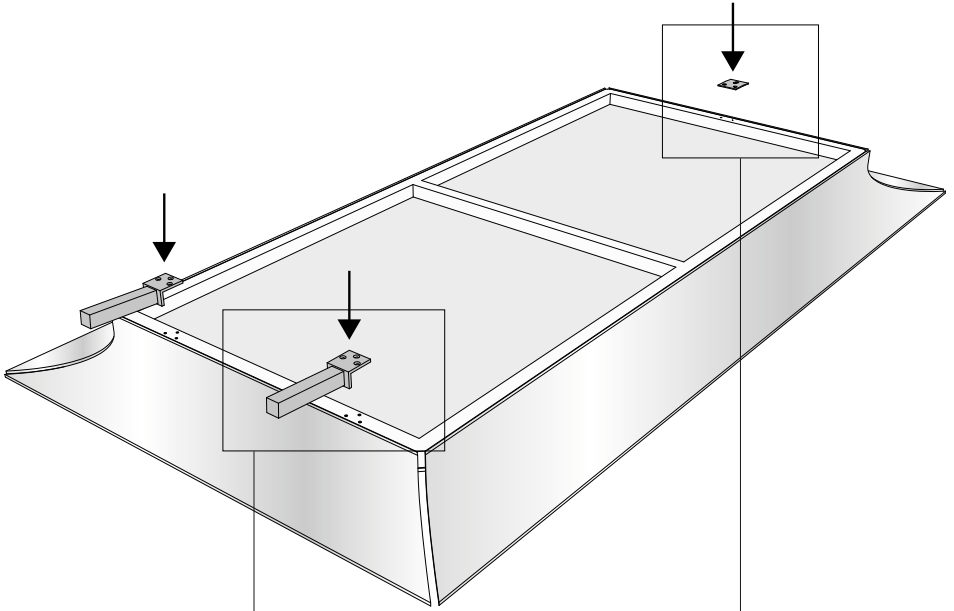

4

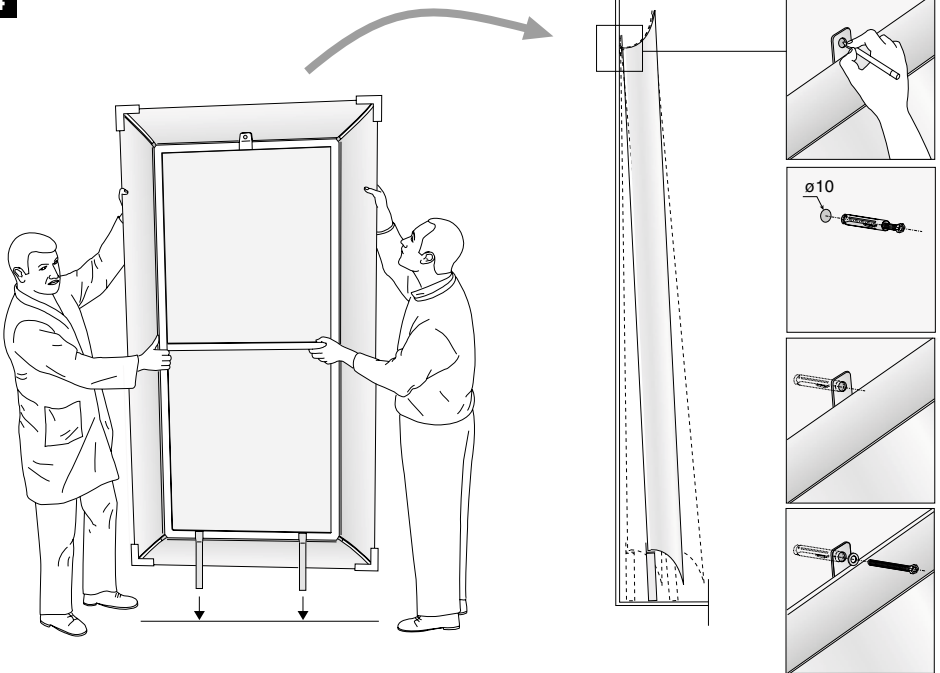

L'altezza di foratura è indicativa. Se si vuole montare lo specchio più o meno inclinato, forare di conseguenza.

The drilling height is only a suggestion. For a different inclination, drill accordingly.

La hauteur du trou est seulement indicative. Pour avoir une inclinaison différente, prévoir un trou à la hauteur désirée.

Die Bohrunghöhe nur anzeigend. Zu einer verschiedenen Stellung-mehr/ weniger schräg, die Bohrung auf der entsprechenden Höhe vorzubereiten.

5

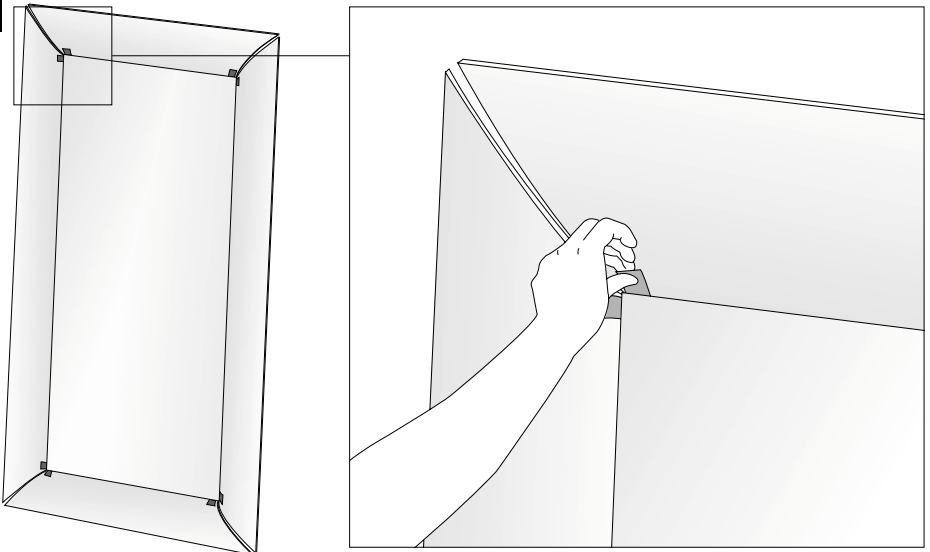

Art. 300 - 400 - 444 - 500 - 610 - 612 - 640 - 645 - 650

Read this information carefully before using the product and keep it for future reference. Failure to comply carefully with the instructions which follow may put the safety of the product and its users at risk.

1 Product description and intended use

• Product description and composition

The CAADRE Mirror - Art. Code 300 - 400 - 444 - 500 - 610 - 612 - 640 - 645 - 650 is a Mirror intended as an item of indoor furniture. It is manufactured from curved float plate glass. The CAADRE Mirror was produced at the FIAM ITALIA Srl factory at Via Ancona 1/B, 61010 Tavullia (PU), Italy - Tel: +39.0721.20051 - Fax: +39.0721.202432 - www.fiamitalia.it

• Intended use

The article known as CAADRE is designed and built to serve as a Mirror for indoor use and must therefore be used only for this purpose and no other.

For more information about the product's intended use please refer to section "**2 SAFETY INSTRUCTIONS**".

2 Safety instructions

To ensure that our product is used in the conditions of the utmost safety, we urge you to comply with the safety instructions provided below. If in doubt or if you require further information concerning the use of the product, please contact us on the telephone numbers stated in this document.

• Transporting and storing the CAADRE Mirror in the original packaging

The CAADRE Mirror, in its original packaging, must be transported taking the greatest care to prevent knocks and shaking. It must be stored indoors in a dry place.

Place the CAADRE Mirror in the original packaging, in the horizontal position. The arrows on the label on the packaging must be vertical and pointing upward.

Never place weights or loads in excess of 100 Kg on the original packaging, since exceeding this weight may cause the breakage of the article.

The CAADRE Mirror in the original packaging weighs about 160 kg max (art.444), It must therefore be placed on surfaces capable of supporting its weight.

• Removing the packaging - assembly

To remove the original packaging of the CAADRE Mirror, proceed as follows.

- a) Place the packaging crate horizontal. The arrows on the labels on the outside must be vertical and pointing upward.
- b) Open the packaging crate and remove the sheets of polystyrene. Do not use hammers, saws, cutters or other tools which may damage the CAADRE Mirror.
- c) Remove the CAADRE Mirror from its packaging. At least two people are required for this operation. Wear gloves which assure a good grip on the float glass.
- d) Fix the Mirror to the wall following the instructions provided.

2 Safety instructions

• Incorrect use and Non-recommended use

Below, we provide a series of warnings and examples of incorrect uses or procedures which reduce the safety of the CAADRE Mirror.

The series of warnings and incorrect uses or procedures provided below is purely guideline and does not cover all the possible circumstances for incorrect or non-recommended uses of the CAADRE Mirror, which must be evaluated on each occasion.

Do not sit or stand upon the float glass surface of the CAADRE Mirror.

Do not strike the CAADRE Mirror with hammers or pointed items which may crack or shatter the glass.

Do not use powder detergents or detergents containing abrasives for cleaning the CAADRE Mirror, since they may damage the float glass.

In normal conditions of use, do not tilt the product by more than 10°. Any higher angles might reduce the stability of the CAADRE Mirror.

Never place items at temperatures below -30°C (such as items just taken out of the freezer), or with temperatures above +30°C (such as foods just removed from the oven) on the CAADRE Mirror; exposing the surface to stresses of this kind may damage the glass, reducing its strength and thus its safety level.

Never expose the CAADRE Mirror to intense heat sources (such as stoves or ovens); exposing the table to stresses of this kind may damage the float glass, reducing its strength and thus its safety level. Do not expose the CAADRE Table to temperatures below -10°C or weather; exposure of this kind may damage the glass, reducing its strength and thus its safety level. The CAADRE Mirror should be placed well away from items such as coat racks or ornaments which may accidentally fall onto its surface.

• Moving the Mirror

To ensure that the CAADRE Mirror is moved in the conditions of the utmost safety, we urge you to comply with the instructions provided below:

The Mirror must always be handled by at least two people, wearing gloves which assure a good grip on the float glass.

3 Cleaning and care

• Cleaning

Some household and furniture cleaning products may damage the float glass from which the CAADRE Mirror is made.

When cleaning the glass of the CAADRE Mirror, use a damp cloth or leather with washing up liquid or soft soap if necessary.

Warning: do not use alcohol or solvents. Do not use powder detergents or detergents containing abrasives for cleaning the CAADRE Mirror, since they may scratch the float glass.

• Care

The CAADRE Mirror requires regular care to keep it in peak condition and ensure safety.

If the CAADRE Mirror or any part of it is chipped or broken, contact the producer or the sales outlet where the product was purchased for the technical and shape specifications of the CAADRE Mirror or the damaged part, remembering to quote the identification code and the letter code embossed on the curved element.

4 Disclaimer

The manufacturer refuses all liability for improper uses of the CAADRE Mirror and/or for failure to comply with the contents of this technical information resulting in injury and/or damage.